

TOLERANCES TABLE	
0 - 50 mm	± 2
50 - 200 mm	± 3
200 - 700 mm	± 4
700 - 1.000 mm	± 5
1.000 - 2.000 mm	± 10
> 2.000 mm	± 20

Dimensions in mm

### Technical Data

Collection of benches and benches without backrest which can be made of 2, 3, 4 y 6 meters aprox. That means 3, 4, 6 y 9 sitting places. It is characterized by the possibility to incorporate individual backrests or seats.

#### Materials:

The structure is made of stainless steel rod 12 mm. Seat made of tranverse extruded aluminium. The bench can be complemented with individually seats and semi rigid backrest made of polyurethane high density.

#### Finishes:

The seat is made of extruded aluminium.

The backrest are manufactured in leather like gray polyurethane. For other colors and finishes, please, check with the sales department.

The support of backrest is made of stainless steel. The leg is made of stainless steel rods.

#### Complements:

Backrest 45x230x500 mm. Ref.: DSIN101617

Seat 430x50x500 mm Ref.: DSIN101618



#### Anchoring:

This bench does not require fastening to the floor, although it can be supplied with anchoring and adjustable height system

With the aim of continuously improving its products, the company retains the right of modifying measures, materials or finishes without any previous note. The names, brands and industrial models of the products have been deposited in the legal Register.

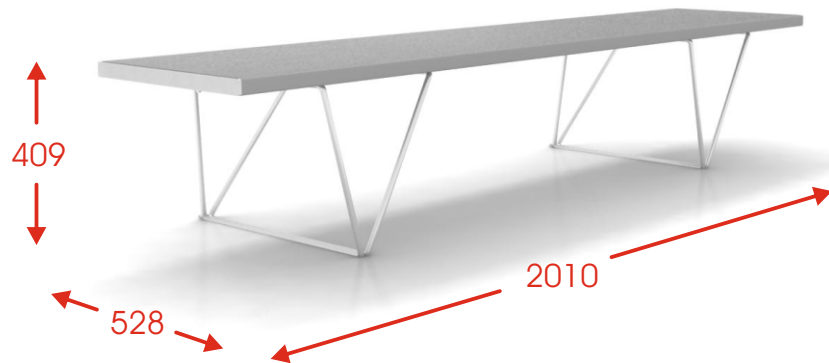

TOLERANCES TABLE	
0 - 50 mm	± 2
50 - 200 mm	± 3
200 - 700 mm	± 4
700 - 1.000 mm	± 5
1.000 - 2.000 mm	± 10
> 2.000 mm	± 20

Dimensions in mm

### Technical Data

Collection of benches and benches without backrest which can be made of 2, 3, 4 y 6 meters aprox. That means 3, 4, 6 y 9 sitting places. It is characterized by the possibility to incorporate individual backrests or seats.

#### Materials:

The structure is made of stainless steel rod 12 mm. Seat made of tranverse extruded aluminium. The bench can be complemented with individually seats and semi rigid backrest made of polyurethane high density.

#### Finishes:

The seat is made of extruded aluminium.

The backrest are manufactured in leather like gray polyurethane. For other colors and finishes, please, check with the sales department.

The support of backrest is made of stainless steel. The leg is made of stainless steel rods.



#### Complements:

Seat 568x50x500 mm Ref.: DSIN101618

#### Anchoring:

This bench does not require fastening to the floor, although it can be supplied with anchoring and adjustable height system

With the aim of continuously improving its products, the company retains the right of modifying measures, materials or finishes without any previous note. The names, brands and industrial models of the products have been deposited in the legal Register.



Approved:	
N° review: 2	Date: 23/11/11

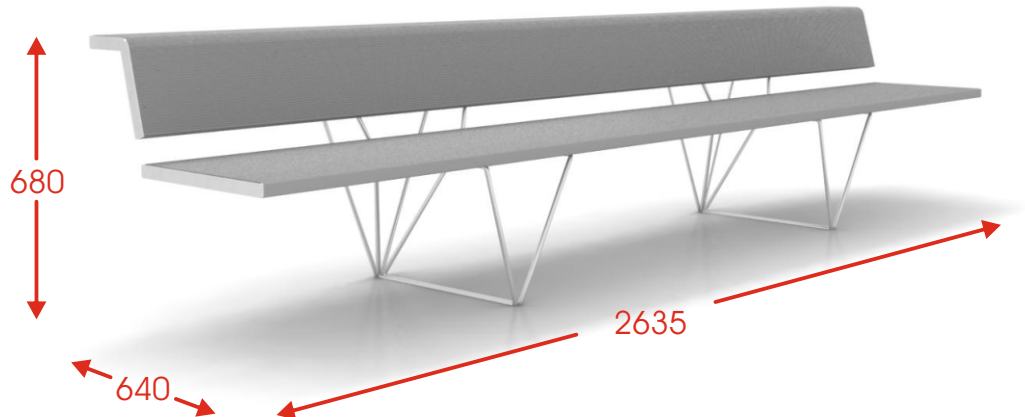

TOLERANCES TABLE	
0 - 50 mm	± 2
50 - 200 mm	± 3
200 - 700 mm	± 4
700 - 1.000 mm	± 5
1.000 - 2.000 mm	± 10
> 2.000 mm	± 20

Dimensions in mm

### Technical Data

Collection of benches and benches without backrest which can be made of 2, 3, 4 y 6 meters aprox. That means 3, 4, 6 y 9 sitting places. It is characterized by the possibility to incorporate individual backrests or seats.

#### Materials:

The structure is made of stainless steel rod 12 mm. Seat made of tranverse extruded aluminium. The bench can be complemented with individually seats and semi rigid backrest made of polyurethane high density.

#### Finishes:

The seat is made of extruded aluminium.

The backrest are manufactured in leather like gray polyurethane. For other colors and finishes, please, check with the sales department.

The support of backrest is made of stainless steel. The leg is made of stainless steel rods.

#### Complements:

Backrest 45x230x500 mm. Ref.: DSIN101617

Seat 430x50x500 mm Ref.: DSIN101618



#### Anchoring:

This bench does not require fastening to the floor, although it can be supplied with anchoring and adjustable height system

With the aim of continuously improving its products, the company retains the right of modifying measures, materials or finishes without any previous note. The names, brands and industrial models of the products have been deposited in the legal Register.

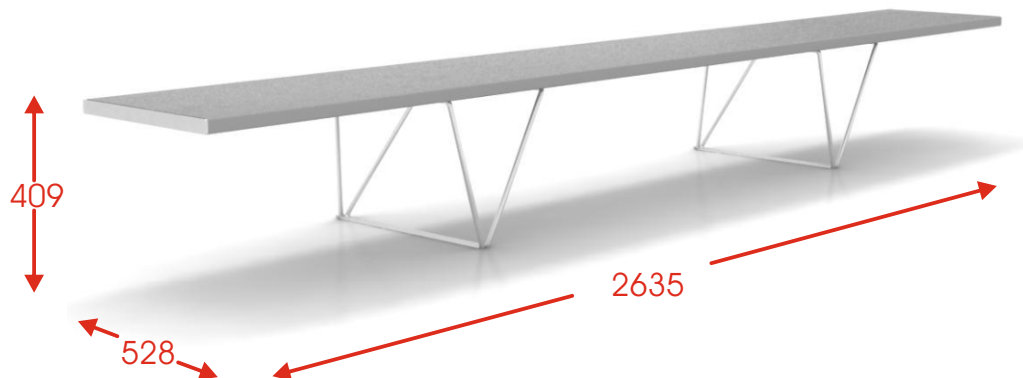

TOLERANCES TABLE	
0 - 50 mm	± 2
50 - 200 mm	± 3
200 - 700 mm	± 4
700 - 1.000 mm	± 5
1.000 - 2.000 mm	± 10
> 2.000 mm	± 20

Dimensions in mm

### Technical Data

Collection of benches and benches without backrest which can be made of 2, 3, 4 y 6 meters aprox. That means 3, 4, 6 y 9 sitting places. It is characterized by the possibility to incorporate individual backrests or seats.

#### Materials:

The structure is made of stainless steel rod 12 mm. Seat made of tranverse extruded aluminium. The bench can be complemented with individually seats and semi rigid backrest made of polyurethane high density.

#### Finishes:

The seat is made of extruded aluminium.

The backrest are manufactured in leather like gray polyurethane. For other colors and finishes, please, check with the sales department.

The support of backrest is made of stainless steel. The leg is made of stainless steel rods.



#### Complements:

Seat 568x50x500 mm Ref.: DSIN101618

#### Anchoring:

This bench does not require fastening to the floor, although it can be supplied with anchoring and adjustable height system

With the aim of continuously improving its products, the company retains the right of modifying measures, materials or finishes without any previous note. The names, brands and industrial models of the products have been deposited in the legal Register.



Approved:	
N° review: 2	Date: 23/11/11

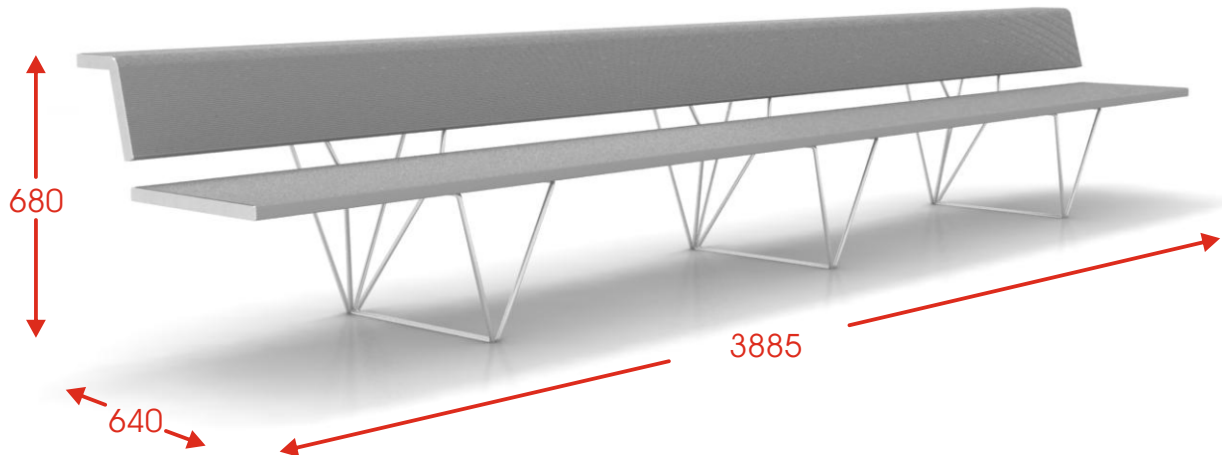

TOLERANCES TABLE	
0 - 50 mm	± 2
50 - 200 mm	± 3
200 - 700 mm	± 4
700 - 1.000 mm	± 5
1.000 - 2.000 mm	± 10
> 2.000 mm	± 20

Dimensions in mm

### Technical Data

Collection of benches and benches without backrest which can be made of 2, 3, 4 y 6 meters aprox. That means 3, 4, 6 y 9 sitting places. It is characterized by the possibility to incorporate individual backrests or seats.

#### Materials:

The structure is made of stainless steel rod 12 mm. Seat made of tranverse extruded aluminium. The bench can be complemented with individually seats and semi rigid backrest made of polyurethane high density.

#### Finishes:

The seat is made of extruded aluminium.

The backrest are manufactured in leather like gray polyurethane. For other colors and finishes, please, check with the sales department.

The support of backrest is made of stainless steel. The leg is made of stainless steel rods.

#### Complements:

Backrest 45x230x500 mm. Ref.: DSIN101617

Seat 430x50x500 mm Ref.: DSIN101618



#### Anchoring:

This bench does not require fastening to the floor, although it can be supplied with anchoring and adjustable height system

With the aim of continuously improving its products, the company retains the right of modifying measures, materials or finishes without any previous note. The names, brands and industrial models of the products have been deposited in the legal Register.



Approved:	
N° review: 2	Date: 23/11/11

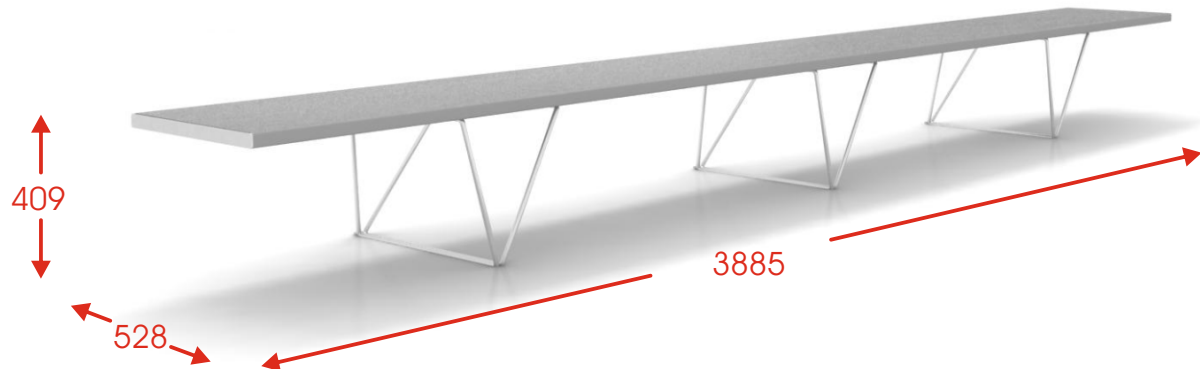

TOLERANCES TABLE	
0 - 50 mm	± 2
50 - 200 mm	± 3
200 - 700 mm	± 4
700 - 1.000 mm	± 5
1.000 - 2.000 mm	± 10
> 2.000 mm	± 20

Dimensions in mm

### Technical Data

Collection of benches and benches without backrest which can be made of 2, 3, 4 y 6 meters aprox. That means 3, 4, 6 y 9 sitting places. It is characterized by the possibility to incorporate individual backrests or seats.

#### Materials:

The structure is made of stainless steel rod 12 mm. Seat made of tranverse extruded aluminium. The bench can be complemented with individually seats and semi rigid backrest made of polyurethane high density.

#### Finishes:

The seat is made of extruded aluminium.

The backrest are manufactured in leather like gray polyurethane. For other colors and finishes, please, check with the sales department.

The support of backrest is made of stainless steel. The leg is made of stainless steel rods.

#### Complements:

Seat 568x50x500 mm Ref.: DSIN101618



#### Anchoring:

This bench does not require fastening to the floor, although it can be supplied with anchoring and adjustable height system

With the aim of continuously improving its products, the company retains the right of modifying measures, materials or finishes without any previous note. The names, brands and industrial models of the products have been deposited in the legal Register.



Approved:	
N° review: 2	Date: 23/11/11

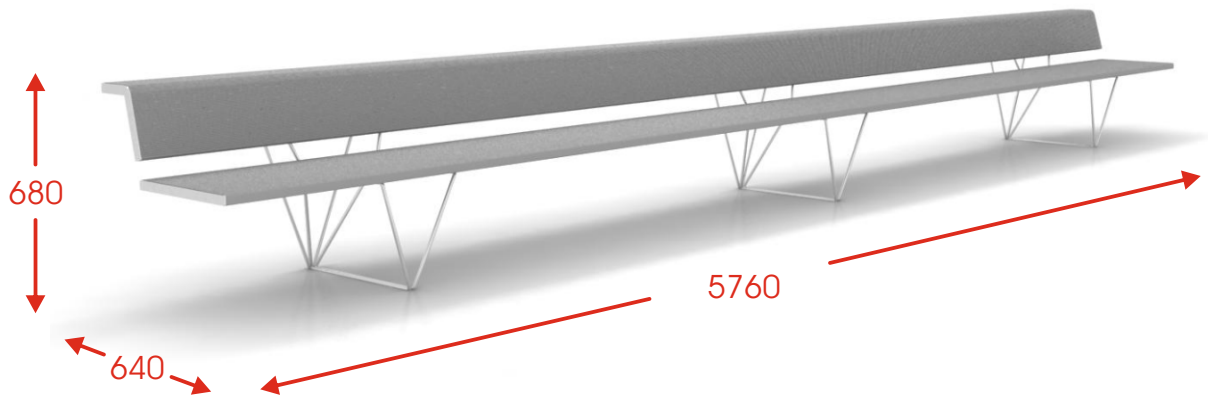

TOLERANCES TABLE	
0 - 50 mm	± 2
50 - 200 mm	± 3
200 - 700 mm	± 4
700 - 1.000 mm	± 5
1.000 - 2.000 mm	± 10
> 2.000 mm	± 20

Dimensions in mm

### Technical Data

Collection of benches and benches without backrest which can be made of 2, 3, 4 y 6 meters aprox. That means 3, 4, 6 y 9 sitting places. It is characterized by the possibility to incorporate individual backrests or seats.

#### Materials:

The structure is made of stainless steel rod 12 mm. Seat made of tranverse extruded aluminium. The bench can be complemented with individually seats and semi rigid backrest made of polyurethane high density.

#### Finishes:

The seat is made of extruded aluminium.

The backrest are manufactured in leather like gray polyurethane. For other colors and finishes, please, check with the sales department.

The support of backrest is made of stainless steel. The leg is made of stainless steel rods.

#### Complements:

Backrest 45x230x500 mm. Ref.: DSIN101617

Seat 430x50x500 mm Ref.: DSIN101618



#### Anchoring:

This bench does not require fastening to the floor, although it can be supplied with anchoring and adjustable height system

With the aim of continuously improving its products, the company retains the right of modifying measures, materials or finishes without any previous note. The names, brands and industrial models of the products have been deposited in the legal Register.

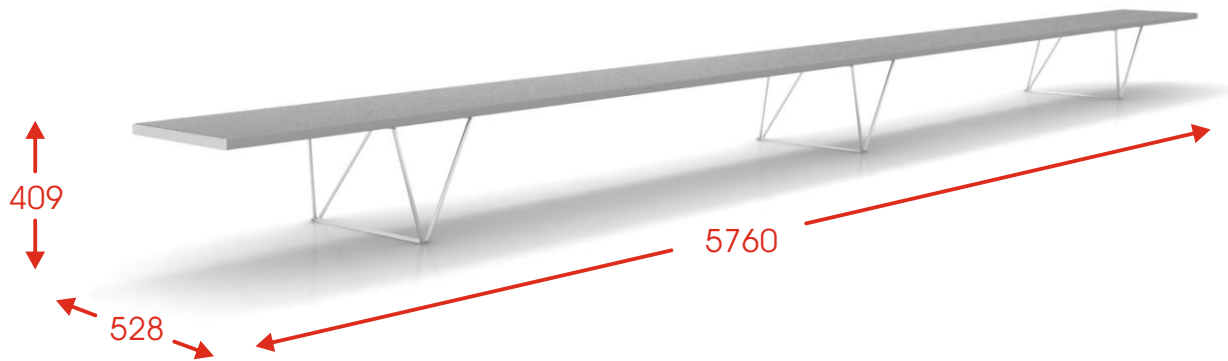

TOLERANCES TABLE	
0 - 50 mm	± 2
50 - 200 mm	± 3
200 - 700 mm	± 4
700 - 1.000 mm	± 5
1.000 - 2.000 mm	± 10
> 2.000 mm	± 20

Dimensions in mm

### Technical Data

Collection of benches and benches without backrest which can be made of 2, 3, 4 y 6 meters aprox. That means 3, 4, 6 y 9 sitting places. It is characterized by the possibility to incorporate individual backrests or seats.

#### Materials:

The structure is made of stainless steel rod 12 mm. Seat made of tranverse extruded aluminium. The bench can be complemented with individually seats and semi rigid backrest made of polyurethane high density.

#### Finishes:

The seat is made of extruded aluminium.

The backrest are manufactured in leather like gray polyurethane. For other colors and finishes, please, check with the sales department.

The support of backrest is made of stainless steel. The leg is made of stainless steel rods.

#### Complements:

Seat 568x50x500 mm Ref.: DSIN101618



#### Anchoring:

This bench does not require fastening to the floor, although it can be supplied with anchoring and adjustable height system

With the aim of continuously improving its products, the company retains the right of modifying measures, materials or finishes without any previous note. The names, brands and industrial models of the products have been deposited in the legal Register.



Approved:	
N° review: 2	Date: 23/11/11